

Snow toughness measurements and possible applications to avalanche triggering

J erome Faillettaz¹, Dominique Daudon¹, David Bonjean¹ and Francois Louchet^{2*}

(1) *Sols, Solides, Structure, St Martin d'H eres (France)*

(2) *LTPCM/ENSEEG, St Martin d'H eres (France)*

Abstract: A snow slab avalanche release usually results from the unstable expansion of a basal crack at the interface between an upper layer (slab) and an underlying substrate, followed by crown crack nucleation and propagation. Despite the fact that many models proposed so far to predict this kind of rupture were only based on continuum mechanics, the use of fracture mechanics seems to be more appropriate to deal with the possible unstable propagation of such defects. For this purpose, a precise knowledge of snow fracture toughnesses in both tensile and shear modes is needed. In the present work, we developed an experimental set similar to Kirchner and Michot's, in order to measure mode I toughness. The experimental campaign carried out in the Alps during the 2000-2001 and 2001-2002 winters on homogeneous sintered snow with different densities gave toughness results of the same order of magnitude as Michot's. However, an unexpected and reproducible dependence of toughness on cantilever length was evidenced. Discrete element simulations of the toughness experiment, considering snow as a cohesive granular material, showed that the elastic energy was stored along a branching pattern. These findings suggest that the classical toughness should be replaced by a generalised toughness defined on the basis of the fractal dimension of this force line pattern.

Keywords: snow, toughness, fractal, avalanches, granular materials

1. Introduction

Most human triggered snow slab avalanches are observed to start from a considerable distance above the skier or the explosive impact locations. There is a general agreement that these triggerings result from a rapid expansion of a so-called basal crack along the slab-substrate interface, that yields a crown crack opening when the tensile load in the slab exceeds its rupture stress. It is therefore of interest to study the stability of a unique basal crack loaded in shear, using the classical concepts of fracture mechanics. According to this scheme, a single crack is being gradually expanded during the skier's motion, and may further expand in a rapid and unstable way as soon as its critical Griffith's size (Griffith, 1920) is reached. The physical parameter involved in this approach is obviously the snow shear toughness, that determines the critical size for basal crack fast expansion. Despite of its interest, snow toughness is very poorly documented in the literature. This is why we performed a series of original field measurements of both tensile and shear toughnesses of this material.

* Corresponding author address: Francois Louchet, LTPCM/ENSEEG, BP 75, 38402 St Martin d'H eres cedex (France), tel: +33 (0)4 76 82 66 09, fax:+33 (0)4 76 82 66 44, e-mail: francois.louchet@ltpcm.inpg.fr

2. Linear elastic fracture mechanics

The aim of fracture mechanics is to define a scalar measure that characterizes stress concentration at the crack tip. The critical value of such a parameter can be used as a size-independent crack instability (i.e. fracture) criterion.

2.1 Griffith's approach

The first theoretical estimation of the influence of the crack was made by Inglis in 1913. The problem with these estimation was that it predicted an infinite stress at the crack tip if the crack was infinitely sharp.

Griffith (1920) proposed an energy based approach. This approach is only valid for ideally brittle continuum materials. Let us suppose, for example, a circular crack of size a in an infinite continuum material loaded in tension (Fig. 1). If the energy needed to open the crack is smaller than the elastic energy relaxed in the sphere, then the crack starts to propagate in an unstable way leading to global failure. This could be written in a first approximation:

$$\left(\frac{\sigma^2}{2E}\right) \frac{d}{da} \left(\frac{4}{3}\pi a^3 da\right) = 2\gamma \cdot 2\pi a da \quad (1)$$

which gives:

$$\sigma\sqrt{\pi a} = \pi\sqrt{2E\gamma} = K_{Ic} \quad (2)$$

where σ is the applied stress, E the Young's modulus, $2a$ the crack length, γ the surface energy

of the material, i.e. the work per unit area of created crack surface, and K_{Ic} the so-called mode I tensile toughness, i.e. the critical value of the stress intensity factor $\sigma\sqrt{\pi a}$ that leads to unstable crack propagation. K_{Ic} is an intrinsic material parameter that only depends on elastic properties of the material (namely the Young's modulus and the surface energy) but is independent of the size and the geometry of the material.

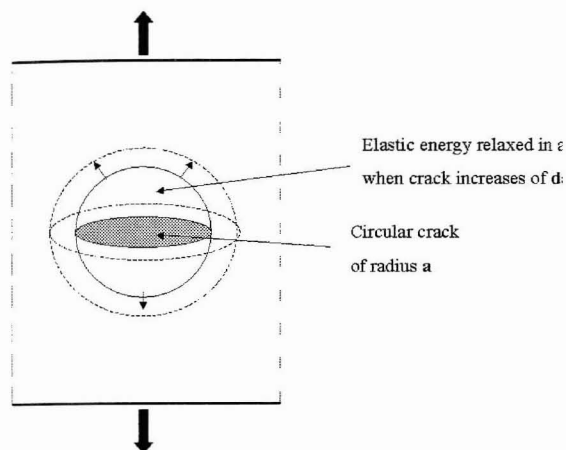

Figure 1: Stability of a circular crack under tensile loading.

As three modes of rupture do exist, three different fracture toughnesses have to be defined: in tension, in shear and in shear out of plane, respectively called mode I, mode II and mode III.

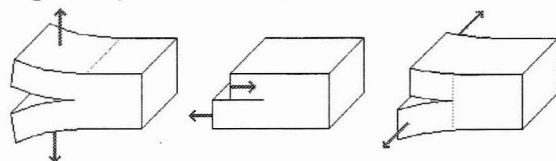

Figure 2: Different rupture modes: mode I or tensile (left), mode II and III or shear modes (center and right).

2.2 Application to snow

If the loading time is short as compared to the time required for significant snow creep (which is the case at least for artificial triggerings), snow can be considered as a brittle material. The condition for basal crack instability is easily shown to be (Louchet 2000):

$$\frac{\rho gh}{2} \sin 2\alpha \sqrt{\pi a_s} = K_{IIc} \quad (3)$$

where ρ is the snow density, h the slab depth measured vertically, α the slope angle, K_{IIc} is the snow shear toughness, and a_s the critical basal crack size for unstable propagation, which is expected to be of the same order of magnitude as the path travelled by the skier when the avalanche is released.

The mode II shear toughness K_{IIc} may be estimated either from failure stress of bulk ice

using the mechanics of porous media (Gibson & Ashby 1988), or from experimental measurements of mode I tensile toughness K_{Ic} assuming snow behaves as a classical dense material (Gibson & Ashby 1988). Both estimates differ by about a factor 20, which leads to a factor of about 400 in basal crack critical sizes (Louchet et al. 2001). This is the reason why we performed in situ toughness measurements.

3. In situ measurements

3.1 Mode I toughness measurements

We based our experimental set up on that of Kirchner et al. (2000). A metallic profile was designed (fig. 3) and introduced horizontally in a snow layer in order to isolate a snow beam from the snow pack. In order to minimise snow-metal adherence, the internal parts of the box were coated with a plastic material classically used for ski soles. The snow beam can be transported conveniently in its container, and is then gently pushed forward to obtain a cantilevered snow beam with a predetermined cantilevered length D . The beam experiences its own weight (fig. 3), no external load being applied. The beam is then cut with a saw along the box edge until the cantilevered portion breaks off. The broken part is collected in a bag in order to determine its weight. The fracture surface (rough) can be clearly distinguished from the cut (smooth), which allows a measurement of the critical crack size a at failure.

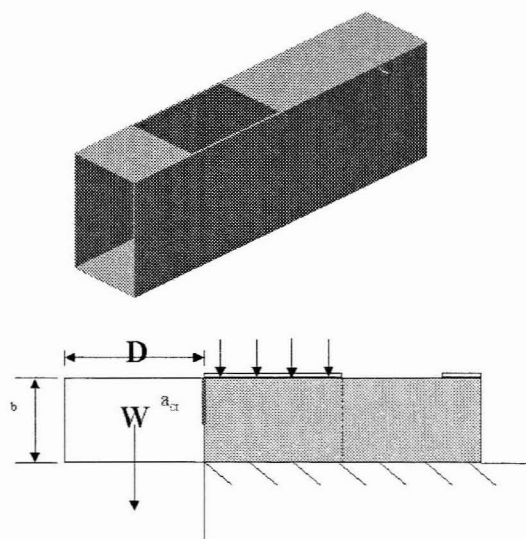

Figure 3: Experimental set-up for snow toughness measurements.

In this particular case, the fracture toughness in mode I is given by (Kirchner et al. 2000):

$$K_{Ic} = 3\sqrt{\pi} F (a_c/b) [WDa_c^{1/2}] / b^2 \quad (4)$$

where K_{Ic} is the tensile fracture toughness, F a geometrical factor depending on both a_c and b but

of the order of unity, W the weight of the cantilevered part of the snow beam, D the cantilevered length, a_c the critical crack length, and b the beam height.

3.2 Experimental results:

The experimental campaign was carried out in the French Alps during the 2000-2001 and 2001-2002 winters on homogeneous sintered snow with different densities from 200 to 350 kg.m⁻³, and for different cantilevered lengths. The results are shown in figs. 4 and 5. Measurements performed on the same layer lead to an uncertainty of about 20%.

Fracture toughness is found around 1000 Pa.√m, i.e. of the same order than Michot and Kirchner's results, taking the same cantilevered length (25 cm). Snow is thus three order of magnitudes more brittle than concrete and six orders more than steel. confirming that snow is the most brittle material known in nature.

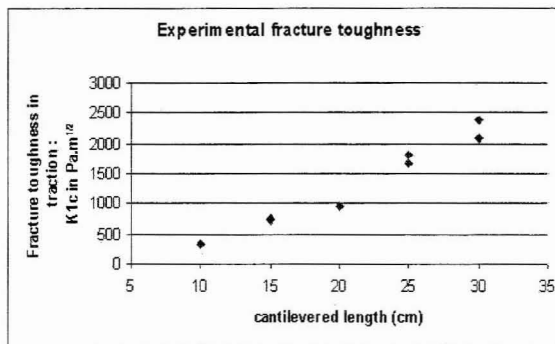

Figure 4: Measured tensile fracture toughnesses for different cantilevered lengths.

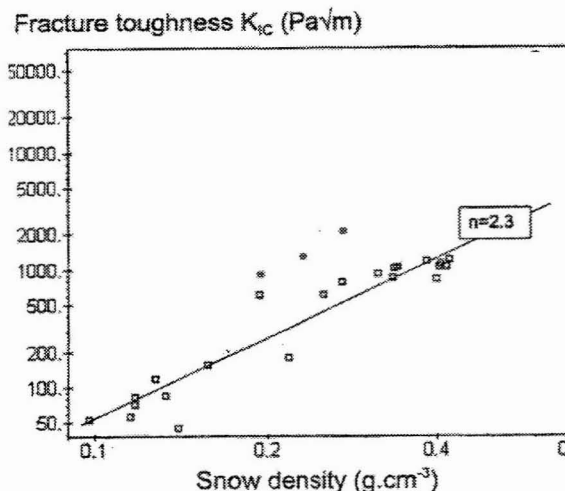

Figure 5: Measured tensile fracture toughnesses for different snow densities, compared with literature (open squares).

A surprising result however is that fracture toughness, which should be an intrinsic parameter,

appears to depend on the cantilevered length. This point will be discussed in § 4.

For practical reasons, variations of toughness with density was measured on 3 different densities only. For too low densities indeed, the beam breaks off before attaining an acceptable cantilevered length (i.e. to be in mode I conditions), whereas for too high snow densities, the experimental box cannot be introduced in the snow pack. In the investigated density range, snow toughness is found to increase with density, in agreement with results from Kirchner et al. (2000) (fig. 5).

3.3 Mode II toughness measurements

Mode II shear fracture toughness (at the interface between the slab and the substrate) is directly involved in the stability criterion of the basal crack (eq. 1). Owing to the layered structure of the snow cover, mode II toughness may significantly differ from mode I tensile toughness measured perpendicular to the layer plane. Using theoretical results from fracture mechanics, it is theoretically possible to deduce shear fracture toughness values from mode I fracture toughness ones, using the elastic constants of the material. However, snow is an heterogeneous and anisotropic granular material in which this calculation is not valid, making direct measurements necessary. A specific set-up dedicated to mode II shear toughness measurements is under construction.

4. Discussion

4.1 Discrete Element modelling

Though our mode I toughness measurements gave results in agreement with literature, an unexpected and reproducible dependence of toughness on cantilever length was evidenced (fig. 4). In order to better understand this point, we decided to model our snow toughness experiment using a discrete element method. Snow is considered as a cohesive granular material. The results are shown in fig. 6.

The crack morphology is reasonably well reproduced. This model is also able to show string forces between grains. We see in particular that the stored elastic energy is not distributed homogeneously in space (unlike assumed in continuum mechanics), but along a branching pattern.

4.2 Why does fracture toughness in tension depends on cantilevered length?

Owing to the relatively large cantilever length used here, the shear component of the stress intensity factor K_{II} is negligible as compared to the tensile component K_I , as discussed by Kirchner et

al. (2002), and cannot account for an apparent variation of K_{Ic} with the cantilever length.

On the other hand, as shown by the discrete element simulations reported above, continuum media assumptions on which the definition of a geometry-independent fracture toughness is based (e.g. eq. 2) are no more valid here.

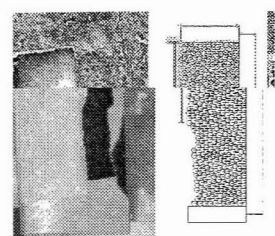
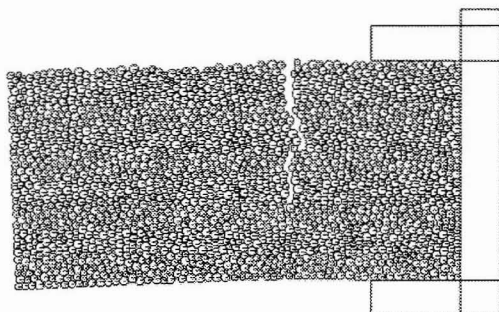

Figure 6: Discrete element simulations of the snow toughness experiment. The crack propagation morphology (top) can be compared with the real experiment (bottom left). The force line pattern is also obtained (bottom right).

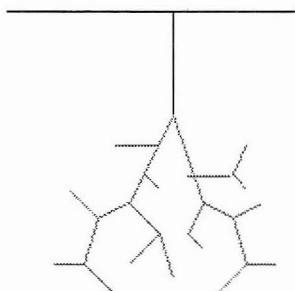

Fig. 7: Schematic fractal string force pattern starting from the tip of an infinitely long crack perpendicular to the figure plane.

A possible explanation for the observed dependence of K_{Ic} on cantilever length may therefore be that the elastic energy is stored along a fractal force pattern instead of being stored homogeneously in the material. Using the same argument as in § 2.1, the stability criterion for the crack schematised in fig. 7 can be written as a balance between the variations per unit length of the elastic energy (stored along a fractal pattern) and the increase of surface energy:

$$\frac{d}{da} \left(\frac{\sigma^2}{2E} \frac{\pi a^\xi}{2} \right) = 2\gamma \quad (5)$$

where ξ is the fractal dimension of the force pattern. A generalised "fractal" toughness may thus be defined as:

$$K_{Ic}^f = \sigma a^{\frac{\xi-1}{2}} = \sqrt{\frac{8\gamma E}{\pi \xi}} \quad (6)$$

The fractal dimension ξ can be obtained by fitting the equivalent of eq. (4) on experimental data in order to obtain a K_{Ic}^f value independent of the cantilever length, and results to be different from 2. Further work is required to relate ξ to the fractal dimension of the material itself.

5. Conclusion

Our in situ snow toughness measurements give promising results, of the same order of magnitude than those by Kirchner et al. (2000). However, these results are shown to depend on the cantilevered length. We propose a possible explanation of this surprising result, based on the fact that the elastic energy in snow is not stored in an homogeneous way as it is in a compact solid, but along a branching pattern, as evidenced by discrete element simulations. A generalised toughness can be defined if this pattern is assumed to have a fractal dimension. Further work is required to relate this generalised toughness to the fractal dimension of snow.

References:

- Gibson L.J., and Ashby M.F. 1987. Cellular Solids: Structure & Properties, Pergamon Press, Oxford.
- Griffith A.A., 1920. The phenomena of rupture and flow in solids. Phil. Trans. of the Royal Society of London, Series A, 221, 163-198.
- Kirchner H.O.K., Michot G., and Suzuki T., 2000. Fracture toughness of snow in tension, Phil. Mag. A, vol. 80, n° 5, 1265-1272.
- Kirchner H.O.K., Michot G., and Schweizer J., 2002. Fracture toughness of snow in shear and tension, Scripta Mater., in press.
- Louchet F., 2000. A transition in dry snow slab avalanche triggering modes, Annals of Glaciology, vol. 32, Symposium on Snow, Avalanches and Impact of the Forest Cover, Innsbruck, Austria, 22-26 may 2000, 2285-2289.
- Louchet F., Failletaz J., Daudon D., Bédouin N., Collet E., Lhuissier J. and Portal A.-M., 2002. Possible deviations from Griffith's criterion in shallow slabs, and consequences on slab avalanche release. XXVI Gen. Assembly of the European Geophysical Soc., Nice, 25-30 march 2001, Natural Hazards and Earth System Sciences, in press.