

The Domestic Water Supply On The Farm

By

H. E. MURDOCK

Agricultural Engineer

MONTANA EXTENSION SERVICE
BOZEMAN, MONTANA

Montana Extension Service in Agriculture and Home Economics,
J. C. Taylor, director. Montana State College and United
States Department of Agriculture cooperating.
Distributed in furtherance of the Acts of
Congress, May 8 and June 30, 1914.

The Domestic Water Supply On The Farm

By

H. E. MURDOCK

Agricultural Engineer

The best time to put modern conveniences into a home is at the time of building. When this has not been done they can still be installed later and give efficient sanitary service. If the different systems are not all put in at the same time they should be installed in the order of their importance in relieving the drudgery of housekeeping.

The four systems needed for making the house modern, given in the order of their importance are: (1) the water supply system, (2) the central heating plant, (3) the sewage disposal system, and (4) the light and power system. These are listed in the order of their installation. However, if a complete water supply distribution system is to be installed, a modern heating plant should be put in at the same time to afford protection from freezing.

A source of water supply for the home is a primary necessity. The most needed modern improvement is the water supply distribution system, as it will greatly lighten the housework, increase the livability of the home, reduce disease and improve the sanitary conditions. A report on conditions in the farm home, made by the U. S. Department of Agriculture, says: "Over and over again it is stated that an adequate water supply in every farmhouse would be the greatest boon that could be given the rural population. The labor involved in carrying for considerable distances all the water required by a large household and then carrying out again all the household's waste is justly described as one of the greatest, if not the greatest, of the farm woman's burdens."

In selecting a site for the farm home, an abundance of good water is of first importance.* It is an absolute necessity for both the household and livestock and always affects the value of the farm.

With a supply of water, the next problem is getting it into the house. Farmers and their families are greatly interested in securing a method better than carrying. This is indicated by the many inquiries concerning the cheapest and best methods of installing a system of running water in the house. It is partly to answer such inquiries that this bulletin has been prepared.

Although much attention has been given to sanitary requirements in the water supplies of cities and towns, not so much has been paid to the water supply for the farm home and to the methods of delivering it. It has been estimated that the average farmer's wife lifts more than a half-ton of water per day. It has also been estimated that the time spent in the unnecessary handling of water, if spent in doing other work, would pay for a water supply system in less than five years, including interest on the investment. Unnecessary handling of water is an added load for an already overburdened member of the household.

Requirements for a Sanitary Water supply

The three fundamental requirements for a sanitary home water supply are **purity, abundance, and convenience**. A supply must be pure to promote health and prevent disease; it must be abundant for personal cleanliness, for washing utensils of the kitchen and dairy, and for the laundry; and it must be convenient to save labor and to be available at all times.

A large majority of the farm water supplies that have been investigated were found to be polluted, and the urban as well as the rural population is suffering from careless or ignorant installation and management of the farm water systems. If disease exists on a farm from which the city obtains food, the disease may be transmitted to the city people consuming those products. Food containers washed in polluted water are dangerous

*In some sections of the arid and semi-arid regions it is very difficult to secure an adequate and suitable water supply, and community cooperation is necessary to bring it into a community by suitable water supply or irrigation ditches or by some other means.

for people using the food conveyed in them, and the urban as well as the rural population should be interested in securing pure water supplies for the country home.

Sources of Domestic Water Supply

The greater portion of the domestic water supply in the country is obtained from wells, springs, and cisterns. In some cases surface streams are utilized, but there is always danger of disease resulting from the use of water directly from them. Such water should be filtered and purified unless it is certain that there is no danger in using it.

Any source of water supply should be located so that the surface drainage will be away from it, especially the drainage from buildings and yards. The location of a spring is not easily changed, but by proper construction a large amount of the pollution that may reach the water supply by direct drainage can be avoided. The earth should be banked up around the spring and the surface water should be carried away from it. It would be unwise to so locate the buildings that the drainage water would flow from them toward a spring which is to be used as the source of the water supply.

The well should always be placed so as to avoid contamination from surface or underground drainage. Mounding the earth around the well and building a high curb will help keep out surface water. The same precautions should be taken with cisterns. The well or spring should not be near cesspools or outbuildings from which polluted water can seep through the soil to the water supply.

Wells

Wells may be classified according to the strata from which the water is obtained, as shallow, deep and artesian. They may also be classified according to the construction, as dug wells and tubular wells.

Shallow wells obtain the water from the strata of earth near the surface of the ground and the supply may be largely replenished by local rains. Deep wells obtain water from strata at considerable depth, and the source of the supply may be

near the site of the well or at a great distance from it. Artesian wells secure the water from a water-bearing stratum in which the water is under pressure that forces it upward in the well when the stratum is tapped. Artesian water usually has its source at a great distance from the well.

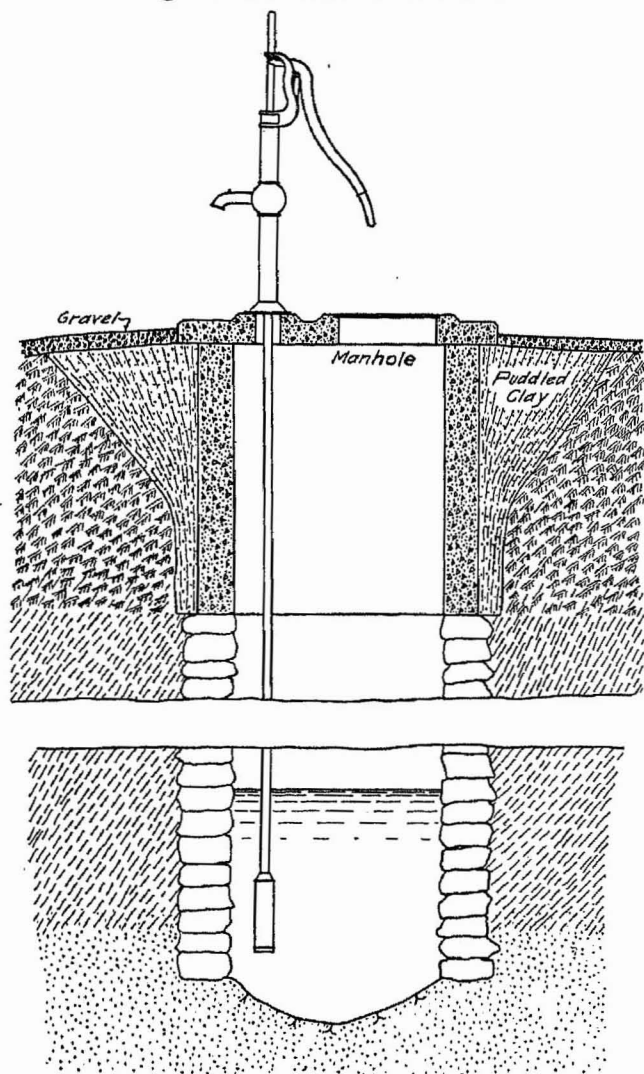

Fig. 1.

The purity of well water depends in a large measure on the type of well supplying it and the strata through which the water passes.

Dug wells are seldom less than 3 feet in diameter, are generally shallow, and lined with masonry. (See Fig. 1.) Tubular wells are usually drilled with a well-drilling rig and may range from a few inches in diameter up to 24 inches or more. Those of large diameter are generally used for obtaining large supplies

of water and are made to admit centrifugal or turbine pumps. Some very deep tubular wells have been drilled, but it is unusual for any water wells to exceed a half mile and the majority are less than 150 feet deep. The deep well is usually tubular. (See Fig. 2.) A type of shallow tubular well is the driven well, which consists of a pipe provided with an iron driving point and a strainer at the lower end. This pipe is driven into the ground until the strainer penetrates a water-bearing stratum, from which the supply is obtained.

From the standpoint of purity of water and freedom from contamination, deep wells are generally purer than shallow wells and tubular wells are generally purer than dug wells. The wells that need to be watched for the purity of the water are those which may receive pollution from surface or underground water draining into them from stables, barnyards, cesspools, and other places of contamination. Contamination also may enter wells in

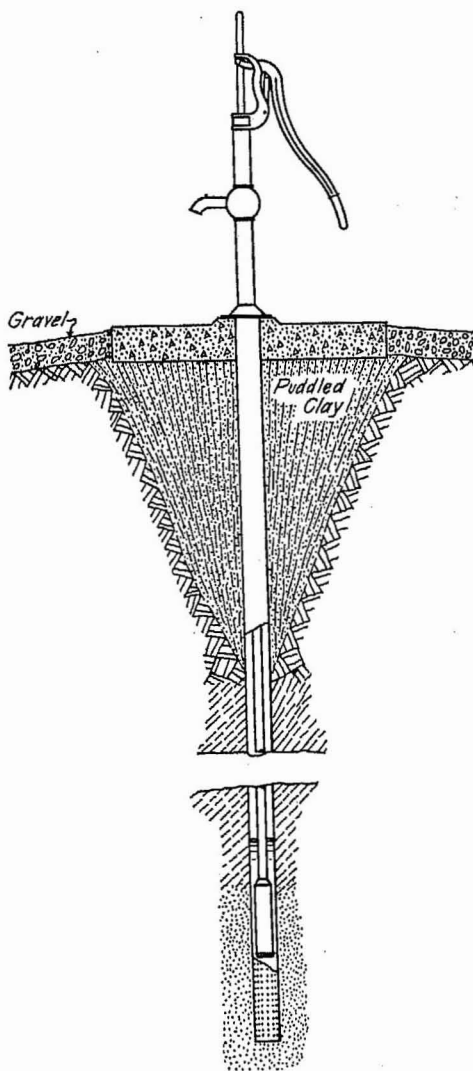

Fig. 2.

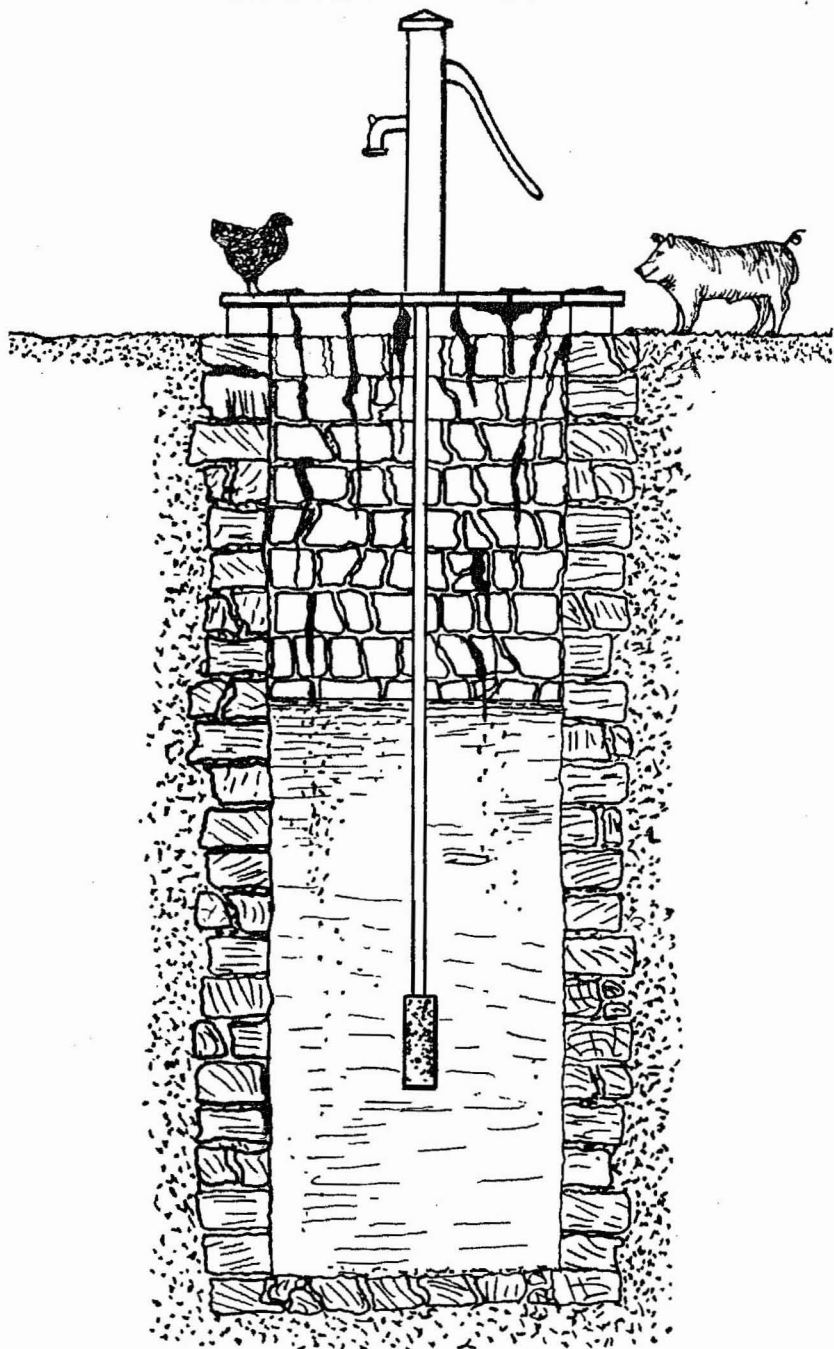

Fig. 3.

a limestone formation where the water runs in underground fissures or caverns the same as it may enter a surface stream. Figure 3 indicates sources of pollution directly from the surface, which is the way the greatest amount enters wells.

Wells can be protected from contamination by avoiding locations toward which the surface drainage naturally flows and by constructing water-tight platforms and water-tight curbs extending below the surface strata to exclude seepage through them. Reinforced concrete curbs, with puddled clay packed around them, form good construction for the protection of well water. Figure 1 shows a dug well and figure 2 a tubular well, both of which are protected from surface pollution.

Springs

In the formation of springs, water percolates through porous layers of the earth until it strikes an impervious layer of rock or clay. Then it runs down over the top of this impervious stratum until it reaches the surface at some lower level, where it bursts forth. Springs may also be formed by water flowing through fissures in rock until it reaches the surface of the ground at some point lower than its origin.

When the water supply is taken from a spring and the spring itself is kept in a sanitary condition, there is usually not much danger of disease germs infecting it. Frequently, however, there are surrounding conditions that render the water dangerous, especially when the spring is found in a swale or a valley toward which the surface waters drain. Unless well protected, springs in such places are likely to become polluted. They are also found in places near which it may be undesirable to build the farmstead. However, if the flow of water is sufficient, a hydraulic ram can be used to force the water to the house even if it is a considerable distance away. In mountainous country, springs and other sources of water supply are sometimes so located that the water may be brought by gravity to the farm buildings and be under pressure there.

Springs can be protected by conducting the surface drainage away from them and by building a water-tight curb with a tight cover. A tile can be built into the curb to serve as a spout.

Cisterns

In portions of Montana where no other good water supply is available, use can be made of cisterns to store the rainfall or water brought in by irrigation ditches. When properly constructed, these furnish a very desirable supply of water for domestic purposes.

It is essential that a cistern be built so as to be free from surface pollution, and the same precautions may be taken as are suggested for wells. If the cistern walls are made water-proof, the only danger of contamination is from surface drainage.

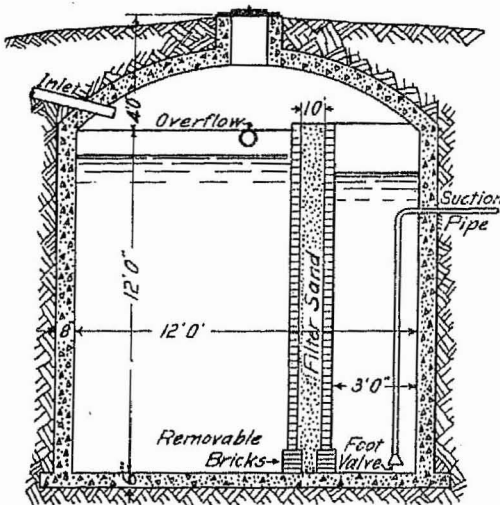
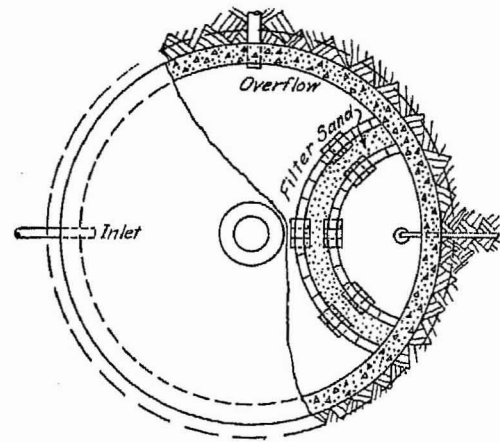

Fig. 4.

Since there are sometimes long periods without any rainfall, the capacity of the cistern should be sufficient to carry the family and stock over such periods. In the case of rainfall the amount of water available for storage depends upon the amount of the rainfall and the roof area from which the water is to be collected. With this information, the size of cistern necessary to hold the water can be determined. Knowing the amount of water neces-

sary for the family and the stock during the period of no rainfall, it can be determined whether the supply from the given area is adequate. Twenty-five gallons a day for each person, 10 gallons for each horse, 12 gallons for each cow, and 1 gallon for each hog or sheep, is a fair average to provide.

The diagrams in figure 4 are plans for a cistern securing its supply from a house 30 feet by 40 feet, where the rainfall is 18 inches a year and comes mostly within a period of 4 months. This cistern will hold sufficient water to carry a family of 5 over a period of 3 months and, with care, a longer period. It will carry this family, 3 horses, 2 cows, some hogs and some poultry for 6 weeks. For a larger family and more stock or a longer period without rain, more roof area and a larger cistern will be required. The cistern shown in the illustration is provided with a filter wall through which all water used for the house must pass. The walls are spaced far enough apart to allow the removal of the filtering material for cleaning.

Another type of filter is shown in figure 5. This is separate from the cistern and is provided with a removable cover to permit replacing the filtering material and cleaning out the sediment.

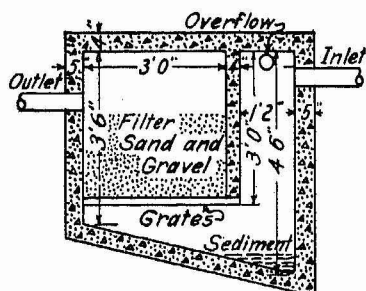

Fig. 5.

A cistern may be built in one corner of the basement or just outside the basement wall, or entirely free from the house. When placed in the basement or near the house, it is easier and cheaper to get the water into the house, but when so located care should be taken to avoid dampness in the basement.

On account of the ease with which a rectangular concrete cistern can be built, it affords rather cheap construction for large capacities. In dry regions where it is necessary to store a large amount of water, this type will be cheaper than the round cistern. The rectangular cistern is usually made 6 to 8 feet wide, 8 to 10 feet deep, and as long as necessary to hold the required amount. A team and scraper may be used to excavate most of the earth,

and the walls may be straightened by hand. Forms for the interior may be made of straight lumber, which can be used for other purposes after the concrete has set. Reinforced concrete walls 6 inches thick will be strong enough to resist the earth pressure when the cistern is empty. If a long cistern is made, cross walls for bracing should be constructed at intervals of 8 or 10 feet. These should not extend entirely to the bottom as space must be left for the water to pass under them.

Water Supply Systems

The purity of the water depends to a certain extent upon the source and the strata through which it passes, but mostly upon the protection afforded by the construction at the source of supply and the care of the water after it is drawn. The abundance depends upon the source and the nature of the water-bearing strata from which the supply is taken and upon the delivery system. A few systems will be discussed in the following pages.

In securing water under pressure there are 3 types of systems in use. These are the elevated tank, the pneumatic or pressure tank, and the auto-pneumatic system.

The elevated tank may be placed in the attic or upon a tower. It will give good satisfaction if heat is provided to protect it from freezing, or if it is insulated so as to be free from danger of freezing. The attic tank may be constructed of galvanized steel, or wood lined with zinc or lead, or of wrought iron. It should be provided with an overflow pipe. If the outside is metal, a drip pan to catch the moisture of condensation should be placed under the tank and connected with the overflow pipe. A barrel may be used temporarily for a tank.

There is danger of making an attic tank too large unless the floor is especially designed to take the load. Although most attic floors may be strong enough to carry the load without exceeding a safe stress, or cracking the plastering, it is well to examine the condition of the floor, beams, studding, etc., before subjecting them to the load. Artificial heat may be provided to keep the tank from freezing.

If an elevated tank is used on a tower, the pipes entering the tank must be well insulated, and the point at which they enter must be especially well protected since it is at this point that most trouble from freezing is experienced. A tower tank may be constructed of wood or of galvanized steel. The pipes leading to it may be protected by building a house around the tower and using a stove for heat, but great care must be exercised to reduce the danger from fire. If a windmill is used for pumping the water, a tank having any capacity up to 2,000 gallons may be supported on the windmill tower as high as 40 feet above the ground. A larger tank should generally have a separate tower.

The pressure or pneumatic tank may be placed in the basement, in the well-house, under the ground, or at some other convenient point where it will be safe from frost. The tank for this system contains both air and water under pressure.

For the auto-pneumatic system an air tank is provided to contain compressed air, and a specially designed pump is located in the well. In this system water is delivered directly from the well to the service pipes without being stored in a tank.

Some systems are better adapted to the use of certain kinds of pumps and motive power than others, although most of them are flexible in this respect. Hand pumps, windmills, small engines, electric motors, and hydraulic rams furnish a variety of equipment that may be used with water supply systems.

Where there is much pumping to be done, a hand pump will prove unsatisfactory because of the large amount of labor required. Considering the reliability of the gasoline engine and the amount of other work it can be made to do around the house, such an engine is recommended for use in connection with a water supply system. Where electric current is available, this makes a most desirable source of power.

When it is feasible to bring water from a spring or other pure source by gravity, this is one of the best methods of obtaining water under pressure. In some instances a storage tank near the buildings may be necessary to provide a sufficient supply for sudden drafts, as in the case of fire, and in other places this may not be needed. To get water in this way, the

spring must be at an elevation sufficient to give the necessary pressure at the building site. The distance such a supply can be conveyed economically depends upon the size and length of supply pipe required and the ditch construction necessary to bury the pipe line to protect it from frost.

The following systems are discussed and illustrated to indicate the variety in equipment that may be installed in the farm home. Approximate bills of materials are also given so that an estimate of the cost of a system may be made when prices of materials are known.

System No. 1

This system is the simplest one illustrated, having only a kitchen sink and a pump with the necessary pipes and connections. (See Fig. 6.) If the water surface is so low that a pitcher pump will not draw the water from the well, a force pump will have to be used. This may be placed low enough in the basement or it may be necessary to put it at the well, in which case

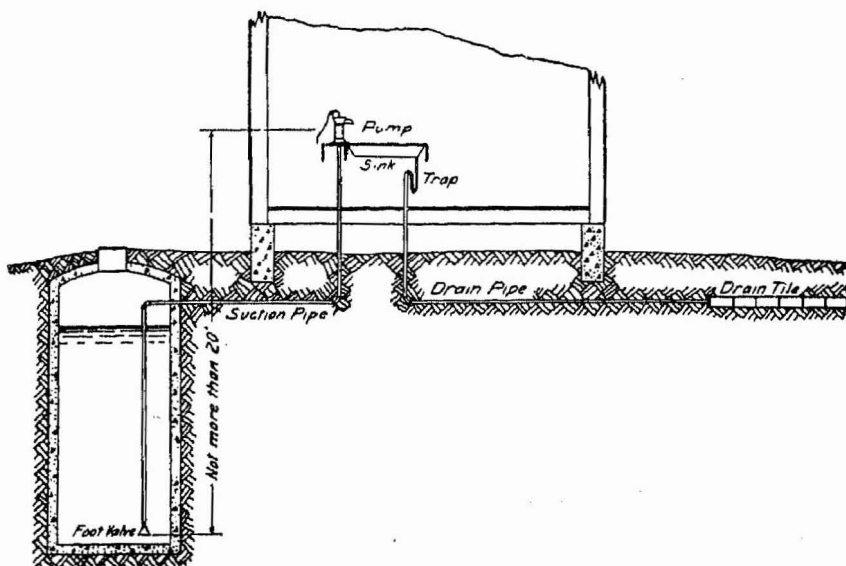

Fig. 6.

a storage tank of some sort should be provided. Figure 7 shows one arrangement where a force pump is used. The pump cylinder will not draw water successfully more than 15 to 20 feet vertically for Montana altitudes.

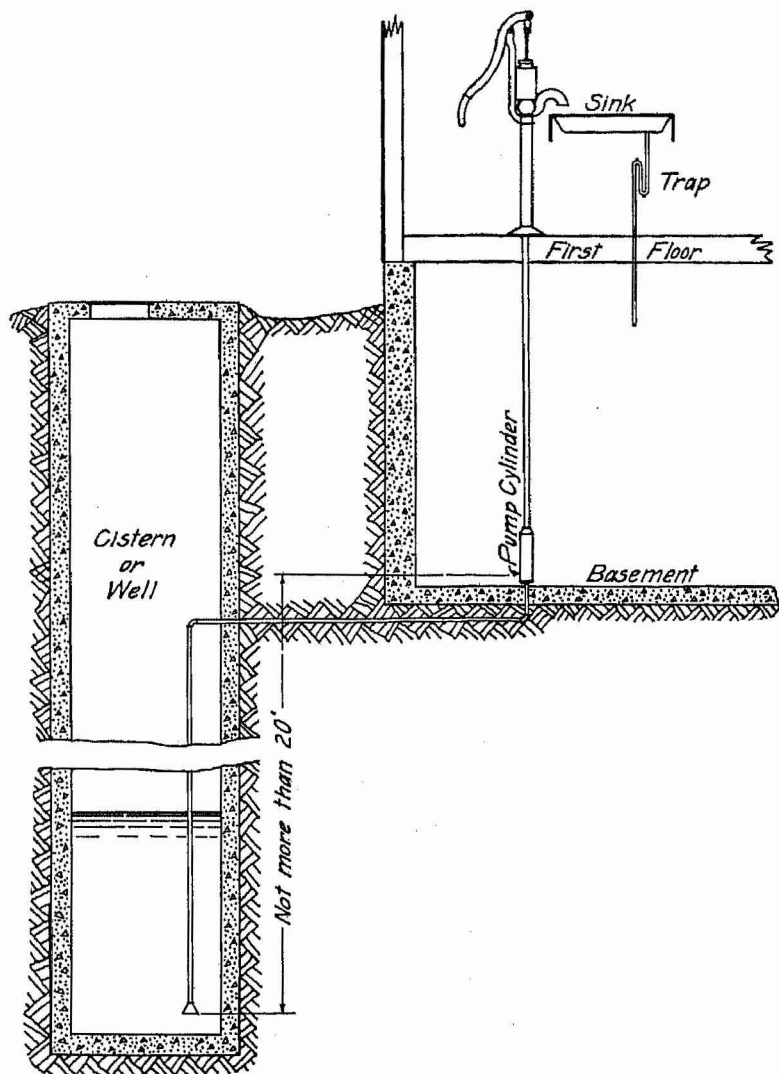

Fig. 7.

The bill of material for this system is as follows:

Thirty feet of 1 $\frac{1}{4}$ -inch galvanized suction pipe (this length depends upon local conditions).

Two 1 $\frac{1}{4}$ -inch elbows.

One 1 $\frac{1}{4}$ -inch foot valve (this may be omitted in some cases).

One pitcher pump (or one force pump).

One kitchen sink and brackets.

Thirty feet of 1 $\frac{1}{2}$ -inch galvanized drain pipe.

One 1 $\frac{1}{2}$ -inch trap.

One 1 $\frac{1}{2}$ -inch elbow.

A line of 4-inch drain tile or a cesspool.

The materials for this system will cost between \$20 and \$35.

System No. 2

In the system shown in figure 8 a force pump is required. In addition to equipment similar to that listed for the first system, this has a bathtub and a range boiler. By the use of this system hot or cold water can be pumped into the kitchen sink or the bathtub, or warm water can be siphoned from the boiler to the sink.

This is made possible by the use of a three-way cock, shown in section at the left side of figure 8. When in the position shown and with the faucet "A" open, cold water is pumped into the sink. If "A" is closed, cold water is pumped into the bathtub. When the three-way cock is turned one-quarter of the way around to the left and the faucet is open, cold water is pumped into the boiler, which forces hot water out through the faucet into the sink; if "A" is closed, the hot water is forced into the bathtub. When the three-way cock is turned halfway around with the faucet open, warm water will be siphoned from the boiler into the sink. With the cock in this position, the boiler full of water, and the faucet "A" closed, the pipes form a circulating system for the hot water which will prevent the freezing of the pipes above the kitchen floor if the fire is banked in the stove over night.

To prevent freezing in the suction pipe, it should be tapped just below the three-way cock and an air-cock screwed in. To drain the suction pipe, the air-cock is opened and the pump handle is raised to the highest position and held there until all the water is drained out. If there is to be no fire in the stove for several days in the winter or in very severe weather when there is danger of the system's freezing, all the water can be drained out by turning the three-way cock one-quarter turn to the left from the position shown in figure 8 and holding the pump handle in the highest position while the water is siphoned from the boiler. After all the water possible is siphoned out, the little remaining in the boiler can be drawn off through the faucet at the bottom. With this arrangement for draining the system, a foot-valve can not be used on the suction pipe.

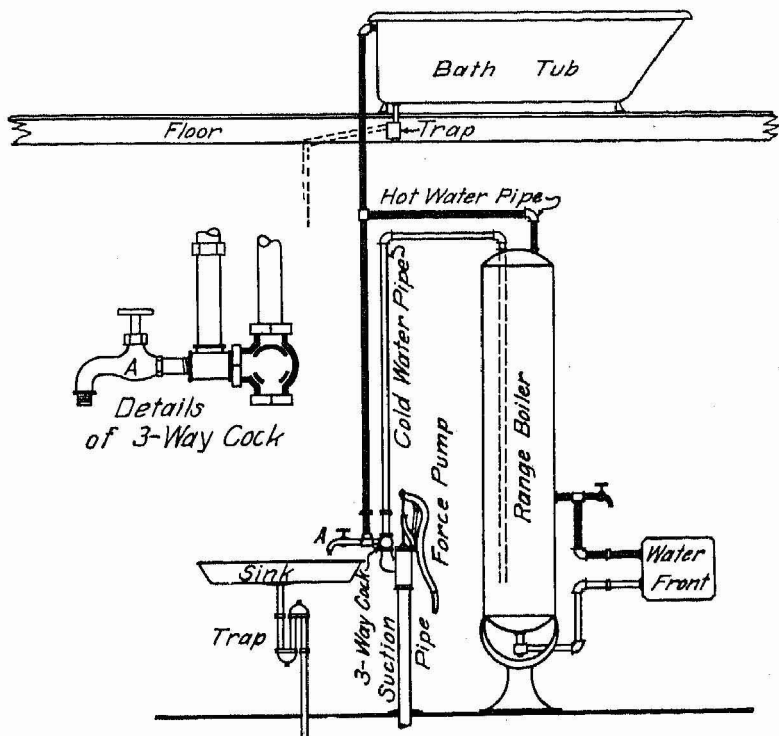

Fig. 8.

The bill of materials for this system includes all items for system No. 1, except the 1¼-inch foot valve. A force pump will be required. In addition, the following materials will be needed:

One range boiler.

One hot-water front.

Twenty-five feet of 1-inch pipe.

Eight 1-inch elbows.

Four 1-inch T's.

Three 1-inch x ¾-inch compression bibs or faucets.

Four 1-inch unions.

One 1-inch three-way cock.

Twelve feet of 1½-inch galvanized drain pipe.

One 4-inch cast-iron drum trap.

One bathtub.

The cost for the materials in this system will be between \$75 and \$100.

System No. 3

In the system shown in figure 9, a pressure tank is indicated in the basement. A hand pump is shown for pumping water into

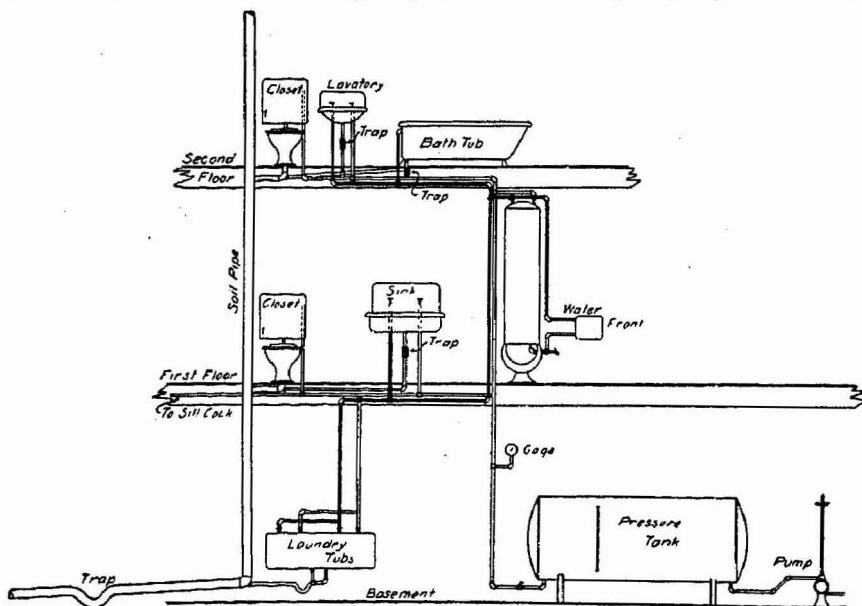

Fig. 9.

the tank, but a small engine or electric motor is recommended for this work. This system includes complete equipment for kitchen, bathroom, laundry and an extra toilet.

Instead of using 1-inch delivery pipe and connections as indicated for system No. 2, $\frac{3}{4}$ -inch connections and pipe are used. In addition to these and the other materials listed for that system, No. 3 will require:

One pneumatic or pressure tank.

One pressure gauge.

One lavatory.

Two toilets.

One set of laundry tubs.

Eight $\frac{3}{4}$ -inch elbows.

Ten $\frac{3}{4}$ -inch T's.

Eight $\frac{3}{4}$ -inch faucets.

Two $1\frac{1}{2}$ -inch traps.

One $\frac{1}{8}$ -inch air-cock.

One hundred feet of $\frac{3}{4}$ -inch pipe.

Thirty feet of 4-inch soil pipe, traps, and Y's.

Without laundry tubs and extra toilet this system can be put in for as low as \$185. With more expensive equipment the cost may run over \$500.

System No. 4

In figure 10 is indicated a system that may appeal to many farmers and will give a great deal of satisfaction for the expense involved. For this system a tank or barrel is used for the range boiler. It is placed in the attic over a partition, which gives added strength to the floor. When a tank is placed overhead, some such precaution as this should be taken to insure safety. The materials required for this system differ very little from those called for in system No. 2. An attic tank or barrel is used instead of the range boiler, and a check valve instead of the three-way cock. This system requires about 15 feet more of 1-inch pipe, an indicating device, and pipe for an air vent. A lavatory is also shown. The cost of this system will not differ much from that of system No. 2.

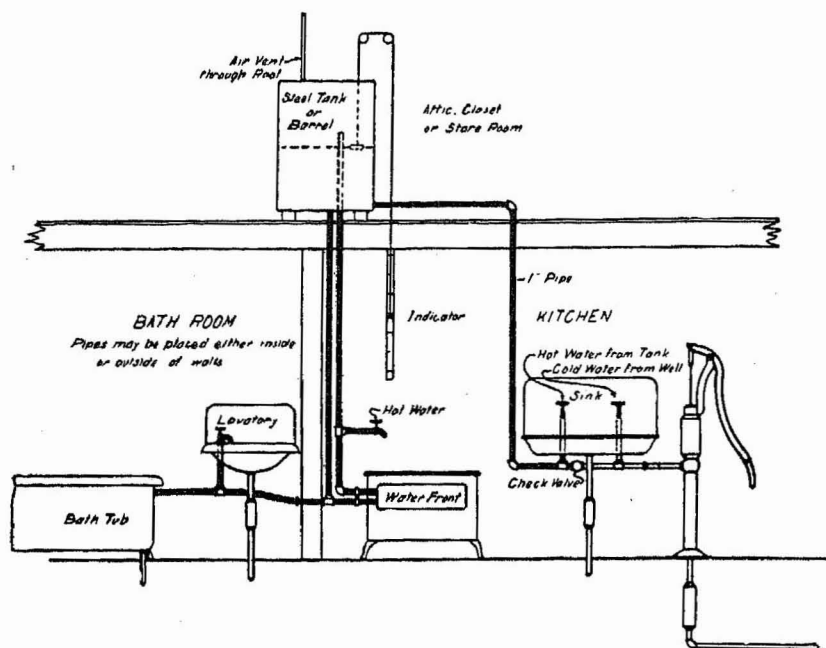

Fig. 10.

Figure 11 shows a view of a kitchen equipped with a simple system for obtaining a warm water supply. This relieves the women of the heavy work of lifting water, but it does not do away with the drudgery of carrying the water into the house. An objection that may be offered is that the barrel occupies valuable space in the kitchen, but if it is located over the fuel box no floor space will be lost. The water level should always be kept above the upper pipe leading from the stove to the barrel. The cost of the materials for this system will be but a few dollars.

Any of the systems shown may be modified to suit individual tastes and to meet the requirements of the house in which it is to be installed. The relative location of kitchen, bathroom, and laundry may necessitate a different arrangement of the piping. A system less complete than No. 3 but more so than the others may be desired, while, on the other hand, one still more elaborate

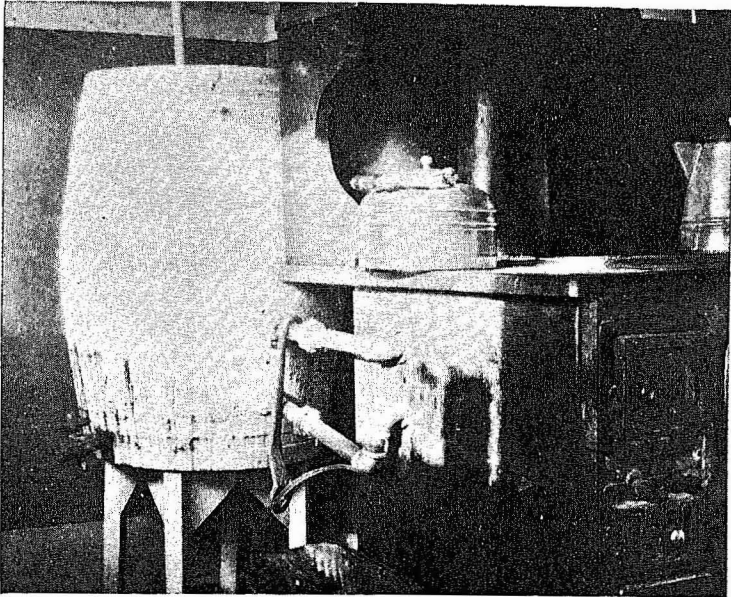

Fig. 11.

than any shown may be desired. For instance, a farmer may want a system to extend to the barn and yards, in which case a tank of larger capacity than any shown, and an engine or motor to pump the water, will be necessary. Or if a large amount of stock is kept, an elevated tower tank of large capacity will be desirable, but it especially should be protected from freezing.

Sewage Disposal

When a complete water supply system such as that shown in No. 3 is installed, some provision must be made for taking care of the waste water and sewage. Whenever sewage from toilets is to be disposed of, a simple drain line will not do the work. In sandy or gravelly soil a cesspool will prove satisfactory for a few years, unless there is danger of contaminating the well or spring from which the domestic water supply is obtained. The leaching cesspool consists of a hole in the ground usually walled with brick laid loosely. The sewage runs into the cesspool and the liquids drain into the soil. In time the pores fill up and the cesspool will

cease to work satisfactorily. The septic cesspool is made tight at the bottom and sides and the liquids drain out into the soil through a tile near the top.

In order to avoid the danger of contaminating the water, sewage should be rendered harmless before it is allowed to escape into the soil. One of the best methods yet devised for the isolated home is that of the septic tank. In this system the liquid and solid wastes are run into a chamber where certain bacteria working in the absence of air liquefy and gasify the solids. When this is completed, the gases escape into the air and the liquids are ready to be further acted upon by bacteria that work in the presence of air and purify the liquids to such a degree that they are no longer dangerous.

Many designs of septic tanks have been proposed, but their relative merits have not yet been determined.* For the first treatment, a concrete or wooden tank is suitable. This may have a second or siphon chamber to hold the liquids until a certain quantity is collected. They can then be discharged automatically into the disposal area to receive a final treatment. This may be had in the natural soil if it is of a sandy or gravelly character, or a filter bed may be required.

The tank shown in figure 12 is one of the simplest and cheapest which seems to give general satisfaction. It consists of a single chamber for the preliminary treatment of sewage. A line of 4-inch drain tile, ranging from 70 to 125 feet in length, is provided for the final treatment. The liquids soak into the soil from the tile line and are acted upon by the oxygen-using bacteria. The size of the tank and the length of tile depend upon the amount of sewage to be treated, and this in turn depends upon the kind of water supply system and the size of the family. The one illustrated is designed for a house with a complete water supply system and a family of five to eight persons. This tank requires 17 sacks of cement, 1.6 cubic yards of sand, 3.4 cubic yards of broken stone or pebbles, six $\frac{1}{2}$ -inch rods 10 feet long and fifteen $\frac{1}{2}$ -inch rods 4 feet long for reinforcement in the top slab.

*For fuller information on sewage disposal, send for Circular No. 74, Sewage Disposal For The Isolated Home, Montana State College Extension Service, Bozeman, Montana.

In addition to this an 18-inch manhole, two 90-degree, 4-inch sewer tile elbows, and an inlet pipe are required. For the disposal area from 70 to 125 feet of 4-inch drain tile is needed. The cost for materials for this system will vary between \$25 and \$45.

The tile line should be laid deep enough to be out of danger from farm implements and to be free from the danger of frost. Under bacterial action heat is evolved which lowers the minimum

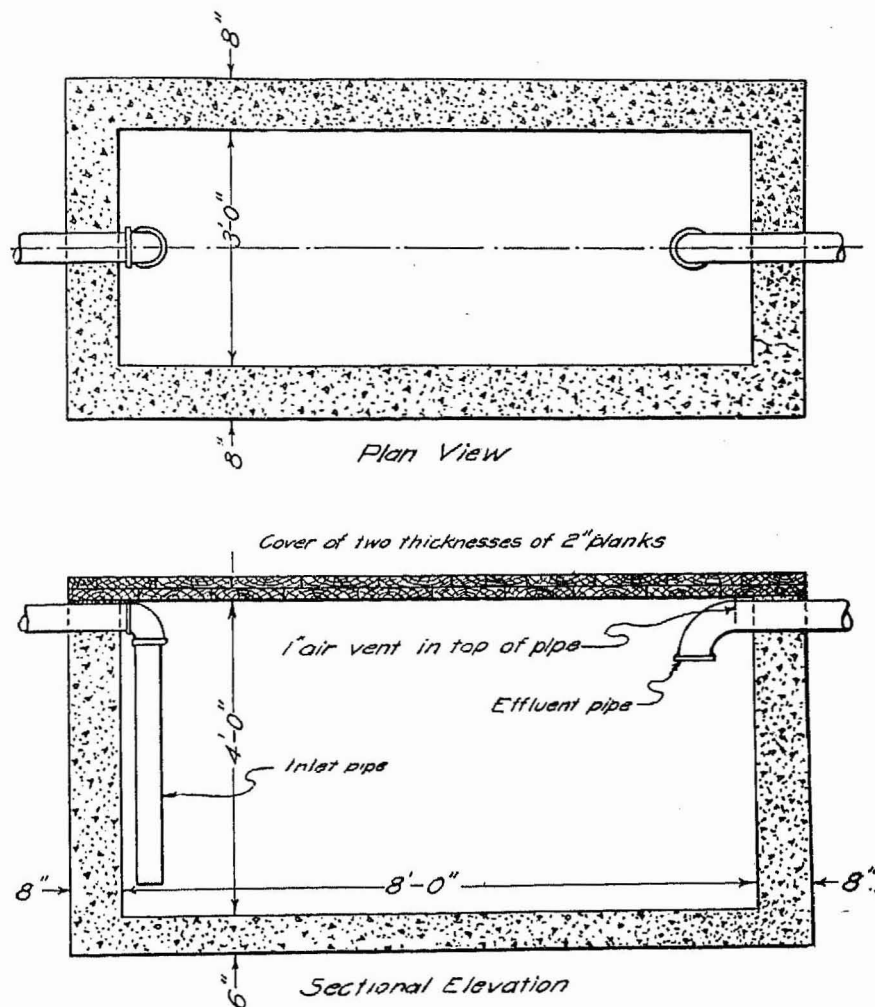

Fig. 12.

outside temperature necessary to freeze the liquids. Some preliminary experiments conducted through two winters indicate that a depth of 14 inches from the ground surface to the top of the tile is sufficient for conditions at Bozeman. The tile should be laid carefully to grade and given a fall of about one inch in a length of 100 feet. If more than one line is used, they should not be closer than 8 to 12 feet. If the soil is of a heavy nature, it may be necessary to place sand, gravel, or cinders a foot or more deep under the tile. If the ground in the disposal area becomes seeped, a drain line parallel to the disposal line may be required to carry off the water, but this will seldom be necessary unless there is a hard-pan subsoil.